

SERIES III DELUXE

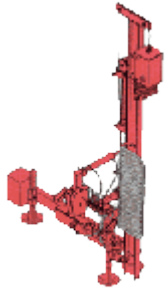

The Post-Driver Legend Started Here!

The Series III King Hitter Deluxe, the 'Postdriver Legend', is the preferred post driver for Professional Fencing Contractors, Vehicle Marker Post and Containment Post Driving, Vineyards, Orchards or wherever a serious post needs driving.

The Series III King Hitter Deluxe displays the excellence in innovative engineering that has made the King Hitter Deluxe name a legend worldwide.

This machine is for the professional Fencer, Contractor, Rancher, or Construction Company where Hydraulic suction and the Driven Post go hand in hand.

Tested in most terrain around the world with exceptional results, the Series III King Hitter Deluxe is a fully counterbalanced side-mounted machine with adjustable balance feet, connected to the standard three-point linkage. All links, side adjustment and angles are determined at the flick of the hydraulic system control lever.

Features and Benefits

- 12' 6", 14', or 16' Girder Construction Steel Mast. The optional mast height is calculated to allow the weight to drop at maximum gravitation speed to produce maximum kinetic energy.
- Big 450 lb, 500 lb, 550 lb and 600 lb weights can produce more than 110,000 lbs of Driving Force.
- Australia 500lb standard, USA 550lb standard, UK 550lb standard. Extra heavy weights must be specified.
- High Tensile 'Live wound' lifting cable for maximum strength and extra life.
- Easily mounts to the right of tractor on standard three-point linkage with counter balance weights to counter side-shift adjustment. All hydraulically operated
- Hydraulic top link has variable adjustment and gives 30° forward and 30° rear movement. The hydraulic side angle adjustment of 25° left or 45° right, quickly allows for accurate post placing on extreme undulating terrain or

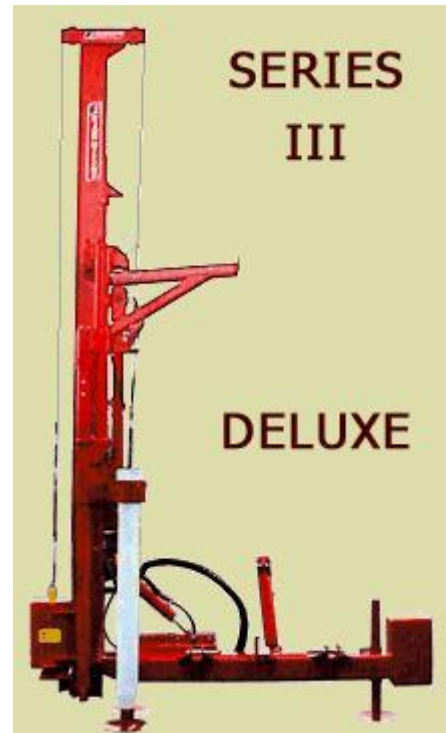

- viticulture angle post fitting.
- Safety Post-cap is standard. This transfers the driving force where it counts, directly into the post.
 - Requires just one person to operate with easy and simple controls.
 - The best warranty's in the business. King Hitter Deluxe is so well engineered it is Covered by the "Fairbrother double the warranty" (conditions apply)
 - Standard Side Mounted The Series III King Hitter Deluxe enables faster, quicker fence post placement by allowing the Tractor to driven parallel to the fence lines.
 - Standard Hydraulic counterbalanced Side-Shift for The Series III King Hitter Deluxe with 450mm(18") adjustment, allows for accurate post placing without unnecessary tractor movements.
 - Optional 'Hinged Mast' is ideal for storage and transportation or where overhead obstructions restrict movement to different fencing areas. (NZ only)
 - Hinged Mast Standard on all 14' and 16' Export only machines.



Mounting	3 point linkage Cat 2
Mast Length	12'6 -14'-16' (3.80 - 4.25-4.88)
Hammers	450-600 lb
Impact	100,000 lbs (45300 kg) See brochure
Tilt Front/Back	30/30 deg.
Tilt Side/Side	25/45 deg.
Legs	Adjustable

Top Link	Hydraulic
Angle Adjustment	Hydraulic
Side Shift	Hydraulic, up to 450mm
Safety Postcap	Yes
Safety Guard	Optional
Safety Hammer Stop*	Optional
Min. Hydraulic Pressure	1800 PSI (12340 kPa) See Brochure
Volume Oil/min.av	6 - 8 GPM
Storage Height:	See Brouchure
Hinged - 12'6" (3.81m) mast	9'10" (3.00 m)
Hinged - 14' (4.27m) mast	10'2" (3.10 m)
Hinged - 16' (4.88m) mast	10'6" (3.20 m)
Shipping Weight	1650-1900lb (748-861 kg)
Shipping Volume	From 46 cu. ft (1.3 cu. m)
Max Post Height	12'6" = 10' 16' = 14'
*standard in Australia and North America	

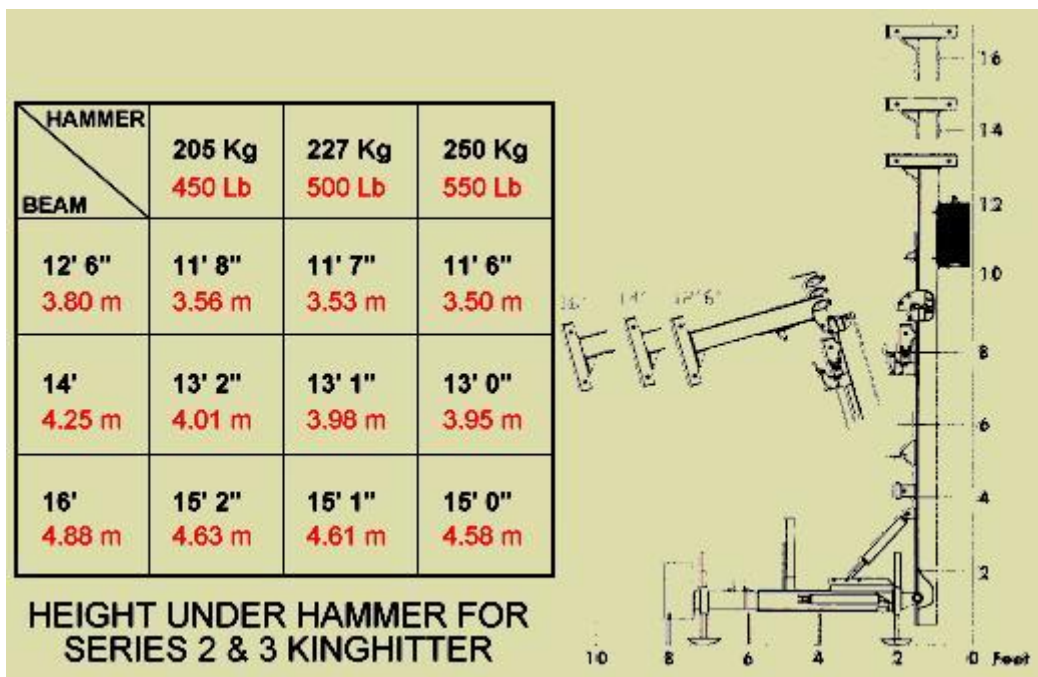

Forgalmazó:



Bentley Magyarország Kft.

H-8000, Székesfehérvár, Seregélyesi út 131

Tel.: 06-22-414-100 Fax: 06-22-414-101

Mobil tel: 06-70-61-61-667

E-mail: matyas@bentleyinstruments.com